

Answer all Questions

Figures in the right hand margin indicate marks

	Answer All questions	
Q.1.	<p>Read the following passage carefully and do as directed.</p> <p>Khairi's story started on October 5, 1974 when 12 Kharia tribals of Similipal brought a two-month old tiger cub to Saroj Raj Chaudhury, an officer in Indian Forest Service, Saroj noticed that it was a female – famished and confused. His first experience what was to become his passion of life was angry snarls and scratching claws. But, the veteran forester and the instinctive lover of wild life knew how to handle a hungry and angry cub. He imitated the sound of a mother tigress. "Within minutes her confidence was firmly anchored in the fostering human," is how he recalled those first few minutes between the legends.</p> <p>At that time, he was an authority on the tiger and Director of Project Tiger in India. Saroj introduced the Tiger Tracing Method of tiger census where the pug marks of each animal with distinctive measurements and characteristics are meticulously recorded. He was also a member of World Wildlife Fund during lifetime.</p>	
A.	Answer the followings briefly:	
i.	When and how Khairi was brought to Mr. Chaudhury?	02
ii.	How Khairi was behaving at that time?	02
iii.	How did Saroj manage the cub?	02
iv.	Make a brief analysis of Saroj Raj Chaudhury's contribution.	02
B.	Find the words from the passage which have the following meanings:	
i.	Very hungry	02
ii.	A strong liking	02
C.	Make sentences using the following words on your own (any one):	
	i. Confuse ii. Handle	02
E.	Supply single word substitute to: Having operations in several countries	02
D.	Make a note of the above passage.	04
Q.2.	Answer the followings:	
i.	Give a description of narrator's final encounter with Red.	02

	ii.	What are the different characteristics of a good team player?	02
	iii.	Describe the Inchcape Rock.	02
	iv.	What makes the poet address her friend “extra-special”?	02
	v.	Why Rover was punished?	02
Q.3.		Do as directed.	
	A.	Fill-in the blanks with appropriate choices given in the brackets.	
	i.	It ___ not happen this way. (may, can)	02
	ii.	There is a temple ___ the river. (besides, beside)	02
	iii.	The club ___ of nine members. (consist, consists)	02
	B.	Change the voice.	
	i.	He loves junk food.	02
	ii.	Do not pluck the flowers.	02
Q.4.	A.	Write a paragraph in about 120 words on any one of the following topics: i. My Institute ii. Energy crisis	05
	B.	Answer any one of the followings: i. You have lost your I Card in institute premises. Draft a notice. ii. Write a report on Tree Plantation Programme conducted in your institute.	05
	C.	Answer any two of the followings: i. You have come back to hostel after a long stay at home during lock down. Now you miss your mother. Draft a letter to her. ii. You are B Sports House, Badadanda, Puri. You have received a packet of torn track suits from your distributor Bombaywalla, Bajrakabati Road, Cuttack. Draft a letter of complaint. iii. You could not attend your sessional exam as you had fever. Now you are fine. Draft an application to your H.O.D. to allow you a chance.	05 X 2
	D.	Shakti Software, Sector-6, Rorkela has invited applications for the post of Maintenance Engineer from diploma holders in Electronics and Telecommunication Engineering. (i)Apply for the post and (ii) enclose your C.V. or Bio-data.	05 + 05
Q.5.		Answer any two of the followings: i. Attempt a discussion on importance of gestures and postures in non-verbal communication. ii. How many types of space you know? Discuss them. iii. Communication follows a dynamic cycle. Explain with help of suitable diagram.	05 X 2

1ST SEM ./COMMON TO ALL BRANCHES/ 2020(W) NEW

TH1-B Computer Application

Full Marks: 80

Time- 3 Hrs

Answer any five Questions including Q No.1& 2

Figures in the right-hand margin indicate marks

1.	Answer All questions	2 x 10
a.	Define pointer in C programming language.	
b.	What is variable in C programming language?	
c.	What is ALU	
d.	What do you mean by non-impact printer?	
e.	Define compiler.	
f.	What do you understand about protocol? Give two examples of protocol	
g.	Define URL with example?	
h.	Compare between file and folder.	
i.	Define GUI .	
j.	Define NULL character constant and NULL statement in C programming language	
2.	Answer Any Six Questions	6 x 5
a.	Compare between 3 rd generation and 4 th generation of computers	
b.	Give a brief description on Email.	
c.	Draw a flow chart to add all the natural numbers from 100 to 200.	
d.	Write about different types of computer virus.	
e.	Discuss about system software and application software	
f.	Explain about different types of mode of data transmission based on direction of data flow.	
g.	Define looping? Write the details about three types of basic looping used in C programming language	
3	Draw a flow chart and write a program in C to add all digits of a given number.	10
4	Define file access? Write on various types of file access methods.	10
5	Write on memory hierarchy system?	10
6	Define topology? Explain various types of topology used to form a network.	10
7	Define Operating System? Write about various types of operating system used in computer	10

**1ST SEMESTER/ COMMON TO ALL BRANCHES/ 2020(W)NEW
TH-2A ENGINEERING PHYSICS**

Full Marks: 80

Time- 3 Hrs

Answer any five Questions including Q No.1& 2
Figures in the right hand margin indicates marks

1. Answer **All** questions 2 x 10
- a. Name the basic units in S.I system.
 - b. Define dot product of 02 vectors.
 - c. What is Dynamic friction?
 - d. Mention the relationship between (i) Linear & Angular velocity (ii) Linear & Angular acceleration
 - e. Define Universal Gravitational Constant (G).
 - f. How are velocity, frequency and time period of a wave related ?
 - g. Define Specific Heat of a substance.
 - h. What is Refractive Index? State its unit.
 - i. Define Unit Charge.
 - j. What does LASER stand for?
2. Answer **Any Six** Questions 5 x 6
- a. Check the dimensional correctness of the physical relations
(i) $s = 6ut + 8at^2$ (ii) $v^2 - u^2 = 9as$ (2.5+2.5)
 - b. At what angle 02 forces (A+B) and (A-B) should be inclined to have a resultant $\sqrt{3A^2 + B^2}$
 - c. What are different methods of reducing friction ?
 - d. Explain the variation of acceleration due to gravity (g) with
(i) Altitude (ii) Depth (2.5+2.5)
 - e. Explain "Critical Angle" and "Total Internal reflection" with ray diagram
 - f. The effective capacitance of 02 capacitors is $4 \mu\text{F}$ when connected in series and $18 \mu\text{F}$ when connected in parallel. Find the capacitance of each capacitor.
 - g. State & explain Coulomb's Law in Magnetism. (2 + 3)
- ANSWER ANY THREE QUESTIONS** 10 x 3
3. Derive formulae for (i) Time of flight (T) (ii) Maximum Height attained (iii) Maximum Horizontal Range of a projectile fired at an angle θ with horizontal. 10
(3+4+3)
4. Obtain equations for (i) Displacement (ii) Velocity (iii) Acceleration of a body executing Simple Harmonic Motion (SHM) 10
(3+4+3)
5. Prove that $\alpha : \beta : \gamma = 1 : 2 : 3$ where α, β and γ are co-efficients of linear, areal and cubical expansion of solid material. 10
6. Establish the condition of balance in a wheatstone bridge using Kirchoff's law with a clear circuit diagram. 10
7. State Faraday's laws of electromagnetic induction. Compare Fleming's Left Hand Rule and Right Hand Rule. 10
(5+5)

Full Marks: 80

Time- 3 Hrs

Answer any five Questions including Q No.1 & 2
 Figures in the right hand margin indicates marks

Answer **All** questions.

2 x 10

1. a. What do you mean by 'penultimate shell'? what is the maximum capacity of this shell to hold electrons?
- b. What are basic salts? Give an example of it.
- c. What happens in the reduction step of metallurgical operation?
- d. Give the bond-line formula of 3-Methylpent-2-ene.
- e. Which chemical substances are responsible for the temporary hardness of water?
- f. Write down the electronic configurations of Cu and Fe³⁺ ion.
- g. What is the major component of CNG? Give one use of CNG.
- h. Name the monomers of Bakelite.
- i. Define insecticides. Give example of an insecticide.
- j. What are lubricants? Give an example of solid lubricant.

2. Answer **Any Six** Questions

6 x 5

- a. Define P^H of a solution. How many grams of NaOH are required to prepare 2 litres of its solution having P^H 12?
- b. Explain electrolysis of aqueous solution of NaCl.
- c. Explain magnetic separation method of concentration of ores with a neat and labelled diagram.
- d. Define hardness of water. Explain cold-lime soda process of removal of hardness of water.
- e. Write a brief note on preparation and uses of Bakelite.
- f. Define and explain Arrhenius theory of acids and bases. What is neutralization reaction?
- g. Write down the IUPAC names/structural formulae of the following.

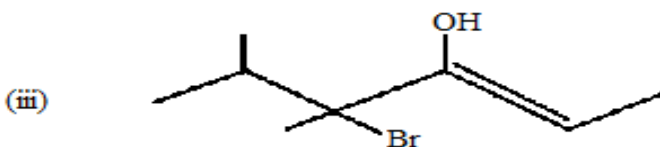
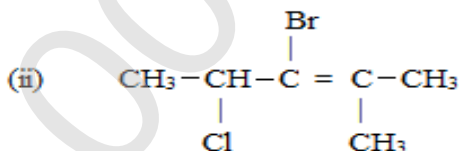
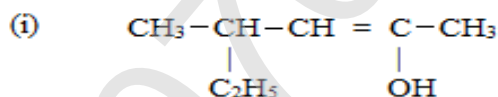

(iv) 4-Bromo-3-methylpent-3-en-2-ol

(v) 2-Methylbuta-1,3-diene

3	(a) Briefly explain 'Bohr's atomic model' for hydrogen atom.	06
	(b) How many grams of $\text{Ca}(\text{OH})_2$ are required to prepare 2.5 litres of its decinormal solution?	04
4	(a) What are lubricants? Write down the purpose of lubrication.	06
	(b) Define herbicide and fungicide with at least two examples from each.	04
5	(a) Write down the composition and uses of producer gas.	05
	(b) Give a brief note on 'Galvanization'.	05
6	(a) Define Faraday's 1 st law of electrolysis. How many grams of silver will be deposited by the passage of 50 ampere of current through silver nitrate solution of 30 minutes?	05
	(b) Define covalent bonding. Explain the formation of CH_4 molecule.	05
7	(a) Define and explain vulcanisation of raw rubber.	05
	(b) Distinguish between saturated and unsaturated hydrocarbons.	05

TH-3 ENGINEERING MATHEMATICS-I

Full Marks: 80

Time- 3 Hrs

Answer any five Questions including Q No.1& 2
 Figures in the right hand margin indicates marks

1. Answer **All** questions 2 x 10
- a. Find the value of $\frac{\sin 15 + \cos 15}{\cos 15 - \sin 15}$
 - b. Find the value of $\tan^{-1} \left(2 \cos \frac{\pi}{3} \right)$
 - c. The maximum value of $\begin{vmatrix} \sin^2 x & \sin x \cos x \\ -\cos x & \sin x \end{vmatrix}$
 - d. Find the value of k if the lines $2x - 3y + 7 = 0$ and $x - ky + 2 = 0$ are perpendicular to each other.
 - e. If $A = \begin{pmatrix} 2 & 4 \\ 3 & 13 \end{pmatrix}$ and $B = \begin{pmatrix} 1 & 5 \\ 2 & -2 \end{pmatrix}$, then find the value of $A - 2B$
 - f. Find centre and radius of sphere $x^2 + y^2 + z^2 - 2x - 2y - 2z - 1 = 0$
 - g. If the distance between the points $(-1, -1, z)$ and $(1, -1, 1)$ is 2, then find the value of z
 - h. Find the image of the point $(3, -1, 5)$ with respect to XY - Plane
 - i. Find the direction cosines of a line whose direction ratios are $(1, 1, 1)$
 - j. Find the Value of $\sin 70 (4\cos^2 20 - 3)$
2. Answer **Any Six** Questions 6 x 5
- a. Solve by Cramer's rule $2x - 3y = 7$ and $3x - 2y = 3$
 - b. Find the equation of circle having centre at $(2, 3)$ and circle passes through the point $(1, 2)$.
 - c. Prove that $\sin 20 \sin 40 \sin 60 \sin 80 = \frac{3}{16}$
 - d. Find angle between the planes $2x + y - 3z + 2 = 0$ and $3x - y + 2z + 3 = 0$
 - e. Find Inverse of the matrix $\begin{pmatrix} 2 & 1 & -2 \\ 1 & 2 & 1 \\ 3 & 6 & 4 \end{pmatrix}$
 - f. If $\tan^{-1} x + \tan^{-1} y + \tan^{-1} z = \pi$ then prove that $x + y + z = xyz$

- g Find the equation of line passing through the point $(2, -4)$ and parallel to the line $4x + y - 3 = 0$
- 3 Prove that without expanding 10
- $$\begin{vmatrix} a - b - c & 2a & 2a \\ 2b & b - c - a & 2b \\ 2c & 2c & c - a - b \end{vmatrix} = (a + b + c)^3$$
- 4 a Find the equation of line passing through intersection of lines $2x - y - 1 = 0$ 5
and $3x - 4y + 6 = 0$ and parallel to the line $x + y - 2 = 0$
- b Find the value of $\sin^{-1} \frac{1}{\sqrt{5}} + \cos^{-1} \frac{3}{\sqrt{10}}$ 5
- 5 Find the ratio and co-ordinate in which the line segment joining the points $(1, 3, -1)$ and $(2, 6, -2)$ is divided by ZX-Plane 10
- 6 Solve by matrix method 10
 $x - y + z = 4, 2x + y - 3z = 0, x + y + z = 2$
- 7 Find the equation of plane passing through the points $(2, -3, 1)$ and $(-1, 1, -7)$ and perpendicular to the plane $x - 2y + 5z + 1 = 0$ 10

**1ST SEMESTER/COMMON/2021(W) NEW
TH1-A COMMUNICATIVE ENGLISH**

Full Marks: 80

Time 03 hours

Answer all Questions

Figures in the righthand margin indicate marks

Answer all questions

- Q.1. Read the following passage carefully and do as directed.
- My grandmother, like everybody's grandmother, was an old woman. She had been old and wrinkled for the twenty years that I had known her. People said that she had once been young and pretty and had even had a husband, but that was hard to believe. My grandfather's portrait hung above the mantelpiece in the drawing -room. He wore a big turban and loose-fitting clothes. His long white beard covered the best part of his chest and he looked at least a hundred years old. He did not look the sort of person who would have a wife or children. He looked as if he could only have lots and lots of grandchildren. As for my grandmother being young and pretty, the thought was almost revolting. She often told us of the games she used to play as a child. That seemed quite absurd and undignified on her part and we treated it like the fables of the prophets she used to tell us. She had always been short and fat and slightly bent. Her face was a criss-cross of wrinkles running from everywhere to everywhere. No, we were certain she had always been, as we had known her. Old, so terribly old that she could not have grown older, and had stayed at the same age for twenty years. She could never have been pretty; but she was always beautiful. She hobbled about the house in spotless white with one hand resting on her waist to balance her stoop and the other telling the beads of the rosary. Her silver locks were scattered untidily over her pale, puckered face, and her lips constantly moved in inaudible prayer. Yes, she was beautiful. She was like the winter landscape in the mountains, an expanse of pure white serenity breathing peace and contentment.
- A. Answer the following briefly:
- i. How did the grandfather appear in his portrait? 02
 - ii. What sort of a person did he look in his portrait? 02
 - iii. How does the author portray his grandmother? 02
 - iv. Why does he say, "the thought was almost revolting?" 02
- B. Find the words from the passage which have the following meanings:
- i shelf 02
 - ii not respectable 02
- C. Make sentences using the following words on your own (any one): 02
- Seem, treat
- D. Supply single word substitute to: 02
- Something which is not logical and sensible
- E. Make a note of the above passage 04
- Q.2. Answer any five of the following: 05×02
- i. What in your opinion was the best lesson that the street taught to the narrator?
 - ii. Explain the expression 'triumphant hatred'.
 - iii. What is the difference between criticizing an idea and criticizing an individual?
 - iv. What is crab mentality?
 - v. Why did Ralph do the wicked act?
 - vi. What does the poet pray for?

- Q.3. Do as directed.
- A. Fill-in the blanks with appropriate choices given in the brackets.
- i. It ----rain tonight. (may, can) 02
 - ii. He is ---- M.A. in English. (a, an) 02
 - iii. There is ----water in the jug. (little, few) 02
- B. Change the voice
- i. He reads newspaper every day. 02
 - ii. Close the door. 02
- Q.4. A. Write a paragraph in about 120 words on any one of the following topics:
- Your college library **or** online class 05×01
- B. Answer any of the following. 05×01
- You are the secretary of students' union. Draft a notice regarding the students' picnic to Puri and Konark for information of students.
- Or
- Write a report on the Blood Donation Camp conducted in your college.
- C. Answer any two of the following: 05×02
- i. Your best friend has won the first prize in the state level debate competition. Write a letter to him/her congratulating him/her on his/her success.
 - ii. You are the owner of Popular Books corner, Grand Road, Puri. You have received a packet of Engineering Mathematics textbooks instead of Communicative English books. Draft a letter of complaint.
 - iii. You are staying in your college hostel. You are facing a lot of difficulties as there is no facilities for drinking water there. Write an application to the superintendent of your hostel requesting him/her to take necessary steps for installing a water purifier in your hostel.
- D. Tata Steel, Kalinga Nagar, Jajpur has invited applications for the post of Junior Engineer from diploma holders in Civil, Electrical and Mechanical Engineering. 10
- (i) Apply for the post (ii) enclose your resume' or C.V. or Bio-data
- Q.5. Answer any two of the following: 05×02
- i. Write a short note on body language.
 - ii. Discuss the types of formal communication in detail.
 - iii. Communication is a circular process. Justify it.

1st Sem / COMMON/ 2021(W) New

Th1(b) Computer Application

Full Marks: 80

Time- 3 Hrs

Answer any five Questions including Q No.1& 2
Figures in the right hand margin indicates marks

1. Answer **All** questions 2 x 10
 - a. Define algorithm?
 - b. What do you mean by GFLOPS
 - c. Write about escape sequence character constant
 - d. Define protocol and give two example of protocol
 - e. Draw the symbols used for I/O statements, decision and general processing to draw a flow chart
 - f. Write two rules for naming a variable in C programming language
 - g. Define CPS
 - h. Write four example of antivirus software
 - i. What do you mean by www
 - j. Define pointer
2. Answer **Any Six** Questions 6 x 5
 - a. Give an account of application software and system software
 - b. Write on star and ring topology
 - c. Describe on types of network
 - d. Compare between time sharing and multi programming operating system
 - e. Draw a flow chart to get smallest number among three numbers
 - f. Explain on register and cache memory
 - g. Write on various types of method of data processing
3. Give an account of generation of computer generation 10
4. What do you mean by operating system? Write the functions of OS 10
5. Define file and folder? Describe about different types of file access method 10
6. Define topology? Write on various types of connecting media used to form a network 10
7. Write a program in C and draw a flow chart to get factorial of a given number 10

1st Sem./ COMMON /2021(W)
Th2 A ENGINEERING PHYSICS

Full Marks: 80

Time- 3 Hrs

Answer any five Questions including Q No.1& 2
Figures in the right hand margin indicates marks

1. Answer All questions 2 x 10
 - a. Write down the SI units of work, angular velocity, electric potential and acceleration
 - b. What are ultrasonics?
 - c. State laws of reflection.
 - d. What is the condition for maximum horizontal range?
 - e. State Newton's law of gravitation.
 - f. State Lenz's law.
 - g. Define specific heat.
 - h. State Fleming's right hand thumb rule.
 - i. Write down the properties of LASER.
 - j. If two capacitors with capacities 2 farad and 3 farad are connected in series connection then, find out the total capacity.

2. Answer Any Six Questions 5X6
 - a. Differentiate between **G** & **g** with example
 - b. State Laws of limiting friction.
 - c. State Kepler's laws of planetary motion.
 - d. Define critical angle and total internal reflection with a diagram.
 - e. Distinguish between longitudinal and transverse wave.
 - f. State and explain Coloumb's Law of electrostatic
 - g. Define lines of force and write down its properties.

3. A projectile fired with an initial velocity 'u' by making an angle 'θ' with the horizontal. Derive expressions for equation of trajectory, maximum height, horizontal range and time of flight. 10

4. Derive an expression for force acting on a current carrying conductor placed in a uniform magnetic field. Distinguish between Fleming's left hand rule & Fleming's right hand rule. 10

5. Find expressions for displacement, velocity and acceleration of a particle executing in S.H.M 10

6. Calculate the total amount of heat required to convert 2.5 Kg of ice from -30°C, to a steam at 200°C. 10

7. State Kirchoff's laws. Apply it to find out balanced condition of the wheatstone bridge. 10

Th2B/Th2 Engineering Chemistry

Full Marks: 80

Time- 3 Hrs

Answer any five Questions including Q No.1& 2

Figures in the right hand margin indicates marks

1. Answer **All** questions 2 x 10
- a. What is copolymer? Give an example of it.
 - b. What are the components of Brass?
 - c. What are the conjugate acid and conjugate base of H₂O?
 - d. Give the bond-line representation of 2-Methylbuta-1,3-diene.
 - e. Write down the electronic configurations of Cu and Ni²⁺ ion.
 - f. Define calcination.
 - g. Which chemical substance is added to LPG in order to detect the leakage of the gas?
 - h. Define electrolyte. Give example of a weak electrolyte.
 - i. Define equivalent weight. Find the equivalent weight of Na₂CO₃.
 - j. Define lubricant. Mention the conditions under which solid lubricants are preferred.
2. Answer **Any Six** Questions 6 x 5
- a. Explain in brief the organic ion-exchange process of removal of hardness of water.
 - b. Explain waterline corrosion.
 - c. Give the IUPAC names/structural formulae of the following.

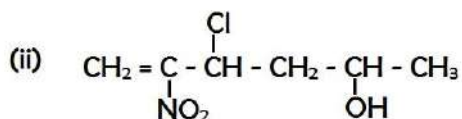
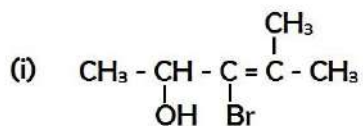

(iv) 4-Bromo-4-chloro-3-methylpent-2-en-2-ol

(v) 3-Chloro-4-nitrohex-3-en-2-ol

- d. Define electrovalent bonding. Explain the formation of NaCl.
- e. Give a brief note on Bio-fertilizer.
- f. Define and explain Hund's Rule.
- g. Describe smelting process in metallurgical operation.
- 3 a 500 ml of an aqueous solution contains 27.75 gm of CaCl₂. Calculate molarity and normality of the solution. 5
- b Distinguish between aliphatic and aromatic hydrocarbons. 5
- 4 a Explain the composition and uses of PVC. 5
- b Discuss the purpose of lubrication 5
- 5 a Define and explain Bronsted-Lowry theory of acids and bases.
- b How many grams of KOH are required to prepare 2 lit. of its solution having P^H 10? 5
- 6 a Explain the drawbacks of natural rubber. 5
- b What are the advantages of hot lime soda process over cold lime soda process? 5
- 7 a Explain froth floatation process of concentration of ores. 5
- b Define and explain Huckel's rule of aromaticity. 5

1st SEMESTER/COMMON/2021(W)(NEW)
Th3 ENGINEERING MATHEMATICS - I

Full Marks: 80

Time- 3 Hrs

Answer any five Questions including Q No.1& 2
Figures in the right hand margin indicates marks

1. Answer all questions 2 x 10
- a. Find M_{23} and C_{32} of the determinant $\begin{vmatrix} 4 & 3 & 8 \\ 6 & 7 & 5 \\ 9 & 0 & 6 \end{vmatrix}$.
- b. Find k for which the following lines are perpendicular to each other
 $2x+3y-1=0$ and $kx-4y+2=0$.
- c. Find $\sin(\tan^{-1} x + \cot^{-1} x)$.
- d. Find the centre and radius of the sphere
 $(x - 2)(x + 2) + y^2 + (z - 3)(z + 3) = 0$
- e. If $\begin{bmatrix} 3 & 4 & 2 \end{bmatrix} \times B = \begin{bmatrix} 2 & 1 & 0 & 3 & 6 \end{bmatrix}$. Find order of B
- f. What is ASTC Rule in Trigonometry?
- g. If the equation $3x^2 - \frac{k}{2}y^2 - 6x + 9y - 3 = 0$ represents a circle, find k.
- h. A line makes angle α, β, γ with X,Y,Z axes, then find
 $\sin^2\alpha + \sin^2\beta + \sin^2\gamma$.
- i. Find the multiplicative inverse of the matrix $\begin{pmatrix} 4 & 3 \\ 5 & 4 \end{pmatrix}$.
- j. Find the intercepts cut off by the plane $2x+3y-z=6$ on the axes.
2. Answer **Any Six** Questions 5X6
- a. Find the angle between two lines whose direction ratios are $\langle 1,2,1 \rangle$ and $\langle 2, -3,4 \rangle$.
- b. Find the equation of the circle whose diameter is the portion of the line $3x+4y-12=0$ intercepted between the coordinate axes.
- c. Prove without expanding
$$\begin{vmatrix} a & a^2 & a^3 \\ b & b^2 & b^3 \\ c & c^2 & c^3 \end{vmatrix} = abc(a - b)(b - c)(c - a).$$
- d. Find the maximum and minimum value of the following
 $6 \cos x - 8 \sin x - 3$
- e. Find the equation of the line which passes through $(-3, 7)$ and makes intercepts on the axes equal in magnitude but opposite in sign.

- f. In a triangle ABC if $m\angle A = 90^\circ$, prove that
 $\tan^{-1} \frac{b}{a+c} + \tan^{-1} \frac{c}{a+b} = \frac{\pi}{4}$, where a, b, c are sides of the triangle.
- g. If $A = \begin{pmatrix} 3 & 2 \\ 2 & 3 \end{pmatrix}$, evaluate $A^2 - 6A + 8I$, where I is the Identity matrix of the given order.

Answer any **three** questions

- 3 a. Find the equation of the line passing through intersection of the lines $x + 3y - 7 = 0$ and $3x - y - 11 = 0$ and centroid of the triangle whose vertices are the points (3,-1), (1, 3) and (2, 4). 5
- b. Evaluate $\sin 18^\circ$. 5
- 4 a. Find the equation of the plane passing through the point (-1, 3, 2) and perpendicular to the planes $x+2y+2z=5$ and $3x+3y+2z=8$. 7
- b. Solve by Cramer's Rule
 $2x+3y=1$ and $-x+y=-3$ 3
- 5 If $A + B + C = \pi$, prove that
 $\sin^2 A + \sin^2 B + \sin^2 C = 2 + 2 \cos A \cos B \cos C$ 10
- 6 Find the equation of a sphere whose centre lies on the plane $x + y + z = 0$ and which passes through the points (1,-3,4), (1,-5,2) and (1,-3,0). 10
- 7 a. Evaluate $\tan^{-1} \left[\frac{\sqrt{1-\sin x} + \sqrt{1+\sin x}}{\sqrt{1-\sin x} - \sqrt{1+\sin x}} \right]$ 6
- b. Find the value of 'a' so that the points (1, 4), (2,7), (3,a) are collinear. 4

1st Sem. COMMON 2021(W) (NEW)

Th 4 a Engineering Mechanics

Full Marks: 80

Time- 3 Hrs

Answer any five Questions including Q No.1& 2
Figures in the right hand margin indicates marks

1. Answer **All** questions 2 x 10

- a. Define force and state its unit ?
- b. State the principle of transmissibility ?
- c. Define FBD with suitable sketch ?
- d. Define Couple and write its unit ?
- e. Define angle of repose ?
- f. What is coefficient of friction?
- g. Differentiate between Centroid and Centre of Gravity ?
- h. Define Mechanical advantage and Velocity ratio by considering a lifting machine ?
- i. Define momentum and impulse ?
- j. Define coefficient of restitution ?

2. Answer **Any Six** Questions 6 x 5

- a. State and prove Lami's theorem.
- b. The resultant of two concurrent forces is perpendicular to the smaller force and angle between the forces is 120° .if the bigger force is 60 N ,find the smaller one?
- c. State the laws of static friction ?
- d. A certain weight lifting machine of velocity ratio 40 can lift a load of 2000 N, with the help of 150 N effort. Determine the efficiency of the machine ?
- e. A smooth circular cylinder of radius 1.5 meter is lying in a triangular groove, one side of which makes 15° angle and the other 40° angle with the horizontal. Find the reactions at the surfaces of contact, if there is no friction and the cylinder weights 100 N.

f. A semicircular area is removed from a trapezium as shown in Fig.(dimensions in mm)

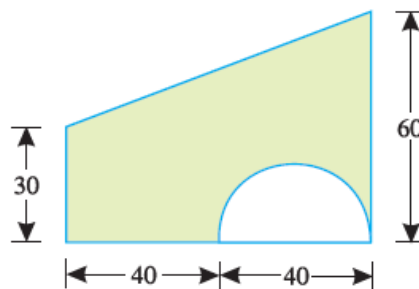

Determine the centroid of the remaining area (shown hatched).

- g A body of mass 40 kg is moving with a constant velocity of 2.5 m/s. Now a force of 100 N is applied on the body in its direction of motion. What will be its velocity after 2 second.
- 3 The following forces act at a point : 10
 (i) 20 N inclined at 30° towards North of East,
 (ii) 25 N towards North,
 (iii) 30 N towards North West, and
 (iv) 35 N inclined at 40° towards South of West.
 Find the magnitude and direction of the resultant force
- 4 A uniform ladder of length 3.25 m and weighing 250 N is placed against a smooth vertical wall with its lower end 1.25 m from the wall. The coefficient of friction between the ladder and floor is 0.3. What is the frictional force acting on the ladder at the point of contact between the ladder and the floor? Show that the ladder will remain in equilibrium in this position. 10
- 5 (a) What is reversible machine? State the condition of reversibility. 5
 (b) What load can be lifted by an effort of 120 N, if the velocity ratio is 18 and efficiency of the machine at this load is 60% ? Determine the law of the machine, if it is observed that an effort of 200 N is required to lift a load of 2600 N 5
- 6 (a) Define Collision .state the law of conservation of linear momentum. 5
 (b) A ball of mass 1 kg moving with a velocity of 2 m/s impinges directly on a ball of mass 2 kg at rest. The first ball, after impinging, comes to rest. Find the velocity of the second ball after the impact and the coefficient of restitution 5
- 7 An I-section is made up of three rectangles as shown in Fig. Find the moment of inertia of the section about the horizontal axis passing through the centre of gravity of the section. 10

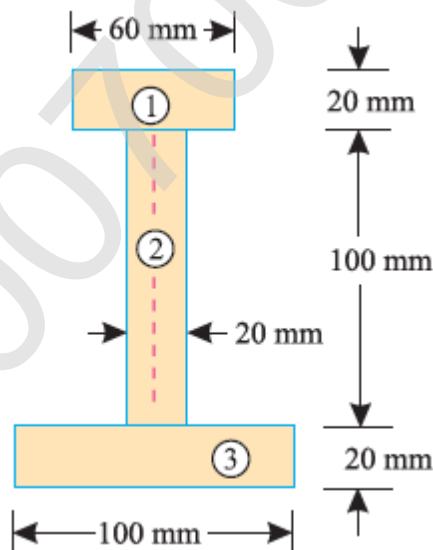

1st Sem./COMMON TO ALL BRANCHES/ 2021(W)
Th4(A&B) Basic Electrical & Electronics

Full Marks: 80

Time- 3 Hrs

Answer any five Questions including Q No.1& 2
Figures in the right hand margin indicates marks

1. Answer **All** questions 2 x 10
- a. What is the function of economiser in thermal power plant?
 - b. Write down basic protective device used in house hold wiring.
 - c. What is the function of commutator in a D.C generator?
 - d. Sketch connection diagram of :-
 - (i) Watt meter
 - (ii) Energy meter
 - e. What is the total resistance of the resistances 2Ω , 4Ω , 6Ω , 8Ω and 10Ω connected in parallel?
 - f. Write down the difference between conductor and semiconductor.
 - g. What is the need of biasing?
 - h. Write down the difference between oscillator and amplifier?
 - i. What is modulation and state different types of modulation?
 - j. What is passive transducer? Write down 2 example of it.

2. Answer **Any Six** Questions 6 x 5

- a. Explain different types of wiring used in Electrical installation.

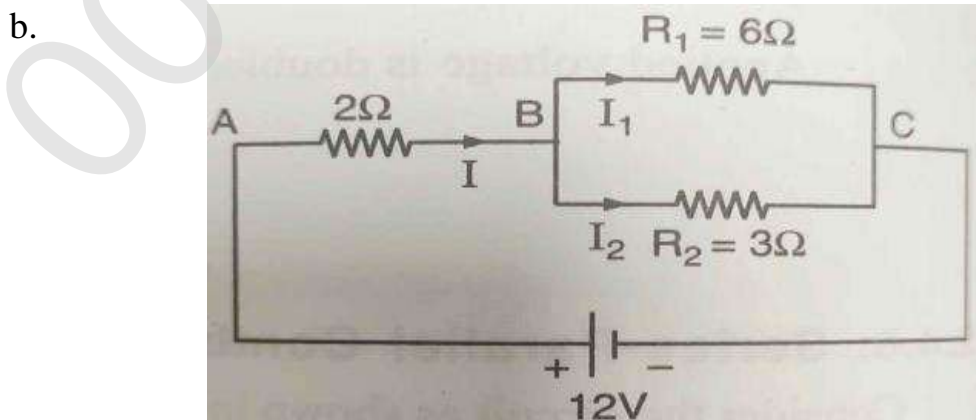

- Find the value of I_1 and I_2 .
- c. Derive the expression for instantaneous current when A.C voltage

- passed through a pure capacitor only.
- d. Define Electronic Emission & explain different types of Emission.
 - e. Explain the working principle of full wave bridge rectifier.
 - f. Explain the concept of transducer and sensor and state the difference between them.
 - g. Explain the working principle of single-phase CE amplifier.
- 3 A resistance of 1Ω , inductance $0.1H$ and capacitance $50\mu F$ are connected in series across a $230V$, 50 Hz supply. Find (a) X_L (b) X_C (c) Z (d) I (e) p.f. (f) active power (g) reactive power (h) apparent power (i) phase angle and Draw impedance and power triangle of Series RLC circuit. 10
 - 4 Explain the working of a hydro power plant with block diagram. 10
 - 5 A house is connected with following electrical loads (i) 2 bulbs 100 watt each running 6hrs daily (ii) 2 tube light 40watt each running 5hrs daily (iii) one heater 1.5KW running 2hrs daily (iv) 4 fans $60W$ each running 10hrs daily (v) One motor 1.5HP running 2hrs daily. Calculate monthly electric bill for August, 2021 if the unit cost is $\text{Rs.}4.20$. 10
 - 6 What is CRO? Explain working principle of CRO with simple Block diagram? 10
 - 7 Explain the working principle and use of PN junction diode with neat circuit diagram. 10

1ST SEM ./ COMMON /2022(W)

Th-4a&b Basic Electrical and Electronics Engineering

Full Marks: 80

Time- 3 Hrs

Answer any five Questions including Q No.1& 2
Figures in the right hand margin indicates marks

1. **Answer All questions** 2 x 10
 - a. Define (i) Lumen (ii) Kirchhoff's Voltage Law
 - b. What do you mean by electron emission? Give an example.
 - c. What is Ohm's Law? Also write the mathematical expression associated with it
 - d. Classify the types of DC Generator.
 - e. Write any two differences between intrinsic and extrinsic semiconductor.
 - f. Define (i) RMS value (ii) Form factor in AC supply.
 - g. If in a DC circuit network, two resistors of 2 ohm and 4 ohm connected in parallel are supplied with 20V DC supply, what will be the voltage drop in 4 ohm resistor?
 - h. What is passive transducer? Give an example.
 - i. Draw the CE configuration of transistor.
 - j. What do you mean by impedance triangle?
2. **Answer Any Six Questions** 6 x 5
 - a. What are the main parts and principle of operation of DC motor?
 - b. Describe about the PMMC type measuring instruments briefly.
 - c. Explain different types of basic filter circuits with proper circuit diagram.
 - d. An AC series RL circuit is made up of a resistor that has a resistance value of 150Ω and an inductor that has an inductive reactance value of 100Ω . Calculate the impedance and the phase angle θ of the circuit.
 - e. Briefly describe the operating principle of LVDT with a neat diagram
 - f. Write a short note on Sodium Vapour Lamp with a neat diagram.
 - g. What are the differences between vacuum tube & semiconductor?
- 3 10

Calculate the electricity bill amount for a month of 30 days, if the following devices are used as specified :

 - (i). 2 Bulbs of 40 W for 6 h/day
 - (ii). 2 Tube lights of 50 W for 8 h/day
 - (iii). 1 TV of 120 W for 6 h/day
 - (iv). 2 fans of 70 W for 8 h/day

Given, the cost of electricity is Rs. 2.5/unit
- 4 Write short notes on (i) Zener Diode (ii) Transistor oscillator 10
- 5 Describe about Amplitude Modulation & Frequency Modulation in details. 10
- 6 Explain about the thermal power station in details with a neat diagram. 10
- 7 Draw and explain the block diagram of CRO and also state its applications. 10

1ST SEM./ COMMON / 2022(W)

Th-1(B) Computer Application

Full Marks: 80

Time- 3 Hrs

Answer any five Questions including Q No.1& 2
Figures in the right hand margin indicates marks

1. Answer **All** questions 2 x 10
 - a. What is Variable and Constant in C programming Language?
 - b. What do you understand by algorithm and flowchart?
 - c. Differentiate between LAN and WAN.
 - d. Name any two network protocol.
 - e. Give example of any four optical input device.
 - f. Write down difference between file & folder.
 - g. What do you mean by Array?
 - h. Define GFLOPS.
 - i. What do you mean by GUI?
 - j. What do you mean by Impact printer and give example.
2. Answer **Any Six** Questions 5 x 6
 - a. Explain about different types of mode of data transmission mode.
 - b. Give comparison between 1st and 2nd generation of computer.
 - c. Differentiate between Primary Memory and Secondary memory.
 - d. Write down various data processing methods.
 - e. Write a program in C to find factorial of a given number.
 - f. Compare between time sharing and multi programming operating system.
 - g. Explain about different generation of programming language.
3. Define file access method and explain about various types of file access methods. 10
4. Briefly explain memory hierarchy system. 10
5. What do you mean by topology? Explain various types of topology. 10
6. What is virus? Explain different types of virus. Write down detection and prevention of virus. 10
7. Define call by value and call by reference with sample C program. 10

1ST SEM ./COMMON /2022(W)
TH1-A COMMUNICATIVE ENGLISH

Full Marks: 80

Time 03 hours

Answer All Questions
Figures in the Right hand Margin indicate Marks

Q.1 **Answer ALL questions.**

Khairi's story started on October 5, 1974 when 12 Kharia tribals of Similipal brought a two-month old tiger cub to Saroj Raj Chaudhury, an officer of the Indian Forest Service. Saroj noticed that it was a female-famished and confused. His first experience of what was to become his passion in life was angry snarls and scratching claws. But, the veteran forester and instinctive lover of wildlife knew how to handle a hungry, angry cub. He imitated the sounds of a mother-tigress. "Within minutes, her confidence was firmly anchored in the fostering human," is how he recalled those first few minutes between the legends.

Early next morning, Saroj started for his inspection of the Tiger Reserve area. I tagged along in the jeep that snaked through narrow road in the woods amidst lush foliage. My mother gave me a gun for my eighth birthday. As a young man, I shot wildlife with abandon. But soon, I realized that there is greater happiness in conserving these beautiful animals that do no wanton harm to man" is one of the things he told me about his life during that long travel.

At that time, he was an authority on the tiger and Director of Project Tiger in India. Saroj introduced the Tiger Tracing Method of tiger and census where the pugmarks of each animal with distinctive measurements and characteristics are meticulously recorded.

A **Give brief answers to the following:**

- i. How and when did Mr. Chaudhury come across Khairi? 02
- ii. In what condition did he find it? 02
- iii. How did he manage the hungry and confused cub? 02
- iv. What was his contribution to the tiger project? 02

B. Find the words from the passage which have the following meanings:

- i Very hungry 02
- ii Reckless harm 02

C. Make sentences using the following words (any one): 02
realise, imitate

D. Supply a single word substitute to: 02
One who pays careful attention to every detail is -----.

E Make a note of the above passage 04

Q.2. **Answer Any Five of the following:** 05×02

- i. What was the best lesson that the street taught to the narrator?
- ii. How did the people in the street respond to the poem written by the narrator?

- iii. What is the joke about the Indian and Japanese workers at the Maruti Suzuki company?
- iv. What are the qualities of a good team player?
- v. How does the poet value her friendship?
- vi. Why did Ralph do the wicked act?
- Q.3. **Do as Directed.**
- A. Fill in the blanks with appropriate choices/ following instructions given in the brackets.
- i. He is ----(a/an) M.A. in economics. 02
- ii. There are ----(a few, a little) students in the class. 02
- iii. You ---- (should/ought to) obey your parents. 02
- iv. When I ----(reach) the station the train----- (already leave) .(Use the correct tense of the verb) 02
- v. Please maintain discipline. (Change the voice) 02
- Q.4. Write a paragraph in about 120 words on any one of the following topics: Knowledge without skill, The things I learnt during lockdown 05×01
- Q 5. Answer any one of the following: 05×01
- You are the secretary of the students' union. Draft a notice regarding a meeting to be held for discussion about annual function for information of all students.
- Or
- Write a report on World Youth Skill Day celebration in your college.
- Q 6. A. **Answer any Two of the following:** 05×02
- i. Write a letter to your friend inviting him to your sister's marriage.
- ii. You are the owner of Reeta Electronics, Bapuji Nagar, Bhubaneswar. You have received a packet of fans instead of mixer grinders. Draft a letter of complaint to M/S Bajaj Electronics, Faridabad, New Delhi.
- iii. Write a letter to the superintendent of your hostel requesting him/her to take necessary steps for the maintenance of water tanks and water purifier of your hostel.
- B. Rourkela Steel Plant has invited applications for the post of Junior Engineer from diploma-holders in Civil, Electrical and Mechanical Engineering. 10
- Apply for the post and enclose your resume' or C.V.
- Q.7 **Answer any Two of the following:** 05×02
- i. Discuss the stages of communication in detail with the diagram.
- ii. Write short notes on body language and communication barriers.
- iii. What is communication and what are the different types of communication?

1ST SEM. / COMMON / 2022(W)

Th-2(a) Engineering Physics

Full Marks: 80

Time- 3 Hrs

Answer any five Questions including Q No.1& 2
Figures in the right hand margin indicates marks

1. Answer **All** questions 2 x 10
 - a. What are the basic units in SI System ?
 - b. State triangle law of vector addition.
 - c. What is the condition for maximum horizontal range for a projectile ?
 - d. Define co-efficient of friction.
 - e. State Newton's law of gravitation.
 - f. Define Simple Harmonic Motion .
 - g. State First law of thermodynamics.
 - h. Write down laws of reflection.
 - i. Three resistors of 2Ω , 4Ω and 5Ω are connected in parallel. Calculate the equivalent resistance.
 - j. Write down the properties of LASER.
2. Answer **Any Six** Questions 5 x 6
 - a. Check the correctness of the physical equation $v = u + at$ by dimensional analysis.
 - b. State laws of limiting friction.
 - c. Differentiate between longitudinal and transverse wave.
 - d. State and explain Coulomb's law of electrostatics.
 - e. State Faraday's laws of electromagnetic induction.
 - f. State Kepler's laws of planetary motion.
 - g. Explain Total internal reflection with diagram.
3. Derive expressions for Equation of Trajectory, Time of flight and Maximum Height for a projectile projected with initial velocity 'u' by making an angle ' θ ' with the horizontal. [4+3+3]
4. State Kirchhoff's laws. Obtain condition of balance for a Wheatstone bridge by applying Kirchhoff's laws. [4+6]
5. How much heat energy is required to convert 7.5 kg of ice at -30°C to a steam at 100°C . Given that the specific heat capacity of ice is $0.5 \text{ cal-gm}^{-1} \text{-}^\circ \text{C}^{-1}$, Specific heat capacity of water is $1 \text{ cal-gm}^{-1} \text{-}^\circ \text{C}^{-1}$, Latent heat of ice is 80 cal-gm^{-1} and Latent heat of water is 540 cal-gm^{-1} . 10
6. Establish a relation between α , β and γ where symbols used carry usual meaning. [10]
7. Write short notes on:- [5+5]
 - (i) Compare Fleming's Right Hand Rule and Fleming's Left Hand Rule.
 - (ii) Properties of magnetic lines of force.

1ST SEM. /COMMON ./ 2022(W)

Th-2 Engineering Chemistry

Full Marks: 80

Time- 3 Hrs

Answer any five Questions including Q No.1& 2
Figures in the right hand margin indicates marks

1. Answer **All** questions 2 x 10
- What are insecticides? Give two examples.
 - Define isotope with suitable example.
 - Mention the basic steps involved in the metallurgical operation.
 - Define Huckel's rule for aromaticity.
 - What is double salt? Give an example.
 - How temporary hardness can be removed?
 - What is degree of polymerization?
 - Define lubricant. Give an example of a semi-solid lubricant.
 - What is Galvanisation?
 - To which class of compound C_4H_{10} belongs and how?
2. Answer **Any Six** Questions 6 x 5
- Define covalent bond. Explain the formation of CH_4 molecule.
 - What are bio-fertilizers? Give some examples.
 - What are the differences between thermoplastic and thermosetting polymers?
 - a. Write the structural formula of the following organic compounds:
 - But-1-en-3-yne
 - 3,4-dimethyl pentan-2-ol
 - Tert-butyl alcohol
 - b. Write the IUPAC name of
 - $CH_3-CH(C_2H_5)-CH(C_2H_5)-CH_3$
 - $CH_3-CH(Cl)CH(Br)CH_2CH(NO_2)CH_3$
 - Explain the froth floatation method of concentration of ores.
 - Define Normality. 4 grams of NaOH are present in 2 litre of its solution. Find its normality and molarity.
 - What is a lubricant? Write the major functions of lubricants.

- 3 a. State and explain Bohr's atomic model. 6 + 4
- b. Write down the composition and uses of Brass and Bronze.
- 4 a. What are saturated and unsaturated hydrocarbons? Is benzene saturated? Justify your answer. 5+5
- b. Explain Bronsted-Lowry Theory of Acid and Bases
- 5 State and explain Faraday's 1st and 2nd law of electrolysis. How many grams of calcium will be deposited at the cathode by passing 15 ampere of currents through molten CaCl₂ for 30 minutes? 4+4+2
- 6 a. Write the composition and uses of PVC. 5 + 5
- b. Define fuel. What are the characteristics of a good fuel?
- 7 a. How hard water can be softened by Ion-exchange process? 6 + 4
- b. Differentiate between calcination and roasting.

1ST SEM ./COMMON / 2022(W)

Th-3 Engineering Mathematics-I

Full Marks: 80

Time- 3 Hrs

Answer any five Questions including Q No.1& 2
Figures in the right hand margin indicates marks

1. Answer **All** questions 2 x 10

a. Find the value of
$$\begin{vmatrix} 1 & bc & a(b+c) \\ 1 & ca & b(c+a) \\ 1 & ab & c(a+b) \end{vmatrix}.$$

b. Find x and y when $\begin{bmatrix} 1 & 3 \\ 2 & -1 \end{bmatrix} \begin{bmatrix} x \\ y \end{bmatrix} = \begin{bmatrix} 4 \\ 1 \end{bmatrix}.$

c. Find the minimum and maximum value of $5 \sin x + 12 \cos x.$

d. Find $\tan\left(\frac{\pi}{4} + 2 \cot^{-1} 3\right).$

e. Determine the ratio in which the line segment joining $(2, -3)$ and $(5, 6)$ is divided by x -axis.

f. Find the perpendicular distance from the point $(2, 1)$ to the straight line $12x - 5y + 9 = 0.$

g. Find the equation of the circle which touches the x -axis and whose centre is at the point $(3, 4).$

h. Find image of the point $(1, -2, 4)$ with respect to YZ -plane.

i. Find the direction cosines of a straight line whose direction ratios are $1, 2, 3.$

j. Find the centre and radius of the sphere
 $3x^2 + 3y^2 + 3z^2 - 12x - 6y + 9z + 1 = 0.$

2. Answer **Any Six** Questions 6 x 5

a. Without expanding prove that

$$\begin{vmatrix} a & a^2 & a^3 \\ b & b^2 & b^3 \\ c & c^2 & c^3 \end{vmatrix} = abc(a-b)(b-c)(c-a)$$

b. Solve the following equations by Matrix Method,
 $x + 2y = 3$ and $3x + y = 4$

- c. Prove that $\sin 10^\circ \cdot \sin 30^\circ \cdot \sin 50^\circ \cdot \sin 70^\circ = \frac{1}{16}$
- d. Find the equation of the straight line which passes through the point (3, 4) and sum of its intercepts on the axes is 14.
- e. Find the equation of plane passing through the point (2, -2, -1) and parallel to the plane $2x + y - 3z - 2 = 0$.
- f. Find the equation of the sphere whose centre at (3, 1, -2) and the sphere passing through the point (1, 1, 2).
- g. If $\tan^{-1} x + \tan^{-1} y + \tan^{-1} z = \pi$, show that $x + y + z = xyz$.

3 a. Solve the following equations by Cramer's Rule, 5
 $2x - 3y + 5 = 0$ and $5y - 3x - 8 = 0$

- b. Find the equation of the plane passing through the intersection of planes $2x + 3y - 4z + 1 = 0$ and $3x - y + z + 2 = 0$, and passing through the point (3, 2, 1). 5

4 a. Find the equation of the circle which passes through the points (1, -2) and (4, -3) and has its centre lies on the line $3x + 4y = 7$. 7

- b. If the point (x, y), (1, -2) and (3, -4) are collinear, 3
 prove that $x + y + 1 = 0$.

5 a. Find the equation of the sphere passing through (1, 2, -3) and (3, -1, 2) and centre lying on X-axis. 5

- b. If $A + B + C = \pi$, 5
 Prove that $\sin 2A + \sin 2B + \sin 2C = 4 \sin A \sin B \sin C$.

6 a. In a ΔABC if $m\angle A = 90^\circ$, prove that $\tan^{-1} \frac{b}{a+c} + \tan^{-1} \frac{c}{a+b} = \frac{\pi}{4}$, 5
 where a , b and c are the sides of the triangle.

b. Verify that $[AB]^T = B^T A^T$, 5
 where $A = \begin{bmatrix} 1 & 2 & 3 \\ 3 & -2 & 1 \end{bmatrix}$ and $B = \begin{bmatrix} 1 & 2 \\ 2 & 0 \\ -1 & 1 \end{bmatrix}$.

7 a. Find the equation of a straight line parallel to the line $2x + 3y + 11 = 0$ and sum of its intercepts on the axes is 15. 6

- b. If $A + B = 45^\circ$, show that $(1 + \tan A)(1 + \tan B) = 2$. 4

1ST SEM./ COMMON / 2022(W)

TH-4 ENGINEERING MECHANICS

Full Marks: 80

Time- 3 Hrs

Answer any five Questions including Q No.1& 2
Figures in the right hand margin indicates marks

1. Answer **All** questions 2 x 10
- Define elasticity.
 - Define force, write down its SI units.
 - What do you mean by kinematics.
 - Define coplanar and collinear forces.
 - Define couple.
 - State perpendicular axis theorem.
 - What is self locking machine.
 - Define centroid.
 - Define Coefficient of Restitution.
 - What is De -Alembert's principle.
2. Answer **Any six** Questions. 6 x 5
- State and prove Lami's theorem.
 - Find the angle between two equal forces of magnitude p , when their resultant is (i) p and (ii) $p/2$.
 - Derive velocity ratio of a compound gear train.
 - Derive the relation between mechanical advantage, velocity ratio and efficiency of a machine.
 - A body of weight 50N is pulled along a rough horizontal plane by a force of 18N acting an angle of 14° with horizontal. Find the coefficient of friction.
 - Find the position of centroid of I-section having following dimensions:
Bottom flange = 300mm x 50mm
Top flange = 150mm x 50mm
Web = 300mm x 50mm
 - A ball of mass 2 kg moving with a velocity of 2 m/s hits directly on a ball of mass 4 kg at rest. The first ball, after impinging, comes to rest. Find the velocity of the second ball after the impact and the coefficient of restitution.
3. Find the moment of inertia of a T-section having flange and web both $120 \text{ mm} \times 30 \text{ mm}$ about X-X axis passing through the centre of gravity of the section. 10

- 4 A uniform ladder 'AB' 3m long weighs 200N. It is placed against a wall making an angle of 60° with the floor. The coefficient of friction between the wall and the ladder is 0.25 and that between the floor and ladder is 0.35. The ladder in addition to its own weight, support a man of 1000N at its top at B. Calculate the horizontal force 'P' to be applied to the ladder at the floor level to prevent slipping. 10
- 5 A simple screw jack has a thread of pitch 12 mm. Find the load that can be lifted by an effort of 20 N applied at the end of handle 500 mm long. Take efficiency of the machine as 50%. 10
- 6 Prove that the moment of inertia of a rectangular section having width 'b' and depth 'd' about x-x axis is $bd^3/12$. 10
- 7 The forces 20N, 30N, 40N, 50N & 60N are acting at one of the angular points of a regular hexagon towards the other five angular points taken in order. Find the magnitude and direction of resultant force. 10